

MOPA 1064-650

Diode pumped passively Q-switched solid state laser

- 1064 nm
- Single Pulse
- ≤ 1.4 ns
- 1 – 1000 Hz
- > 650 μ J
- External/ Internal Trigger Mode

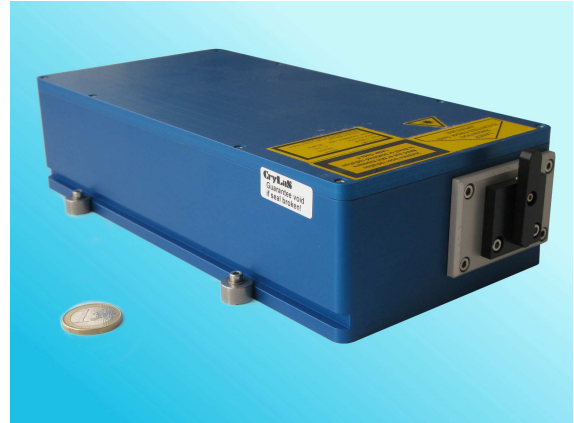

biology · biomedicine · chemistry · analytics

Optical Data	Wavelength	1064 nm
	Peak Power	> 450 kW @ 1000 Hz
	Pulse Energy	> 650 μ J @ 1000 Hz
	Beam Divergence (full angle)	< 3.0 mrad
	Beam Ellipticity	$< 2:1$
	Beam Diameter	1.0 ± 0.3 mm (at laser exit)
	Spatial Mode	TEM ₀₀
	Pulse Repetition Rate (with external trigger)	1 - 1000 Hz
	Pulse Width (FWHM)	≤ 1.4 ns
	Polarization Ratio	$> 100:1$, vertical
	Pulse Energy Stability (averaged over 8 hrs)	± 3 %
	Pulse-to-Pulse Energy Stability (over 60 sec)	± 3 % (< 1 % rms)
	Laser Classification	4 / IV
	Optical Output	Free Beam
Electrical Data	Electrical Power Consumption	< 150 W
	Line Voltage	90 - 265 V AC (50-60 Hz)
Interface	USB	
	BNC connector for external triggering (TTL)	
	SMB connector for 24 V DC output	
Miscellaneous	Warm-up Time	< 10 min
	Operating Temperature	18 - 38 °C
	Laser Head Size	61 x 120 x 314 mm (H x W x L)
	Stand-Alone Unit Size	184 x 343 x 375 mm (H x W x L)
Options	Multimode fiber coupling	
	Synchronization signal output (rise time < 2 ns)	
	Electrical beam blocker	
	External telescope (beam expander) / Electrical or manual attenuator on request	

Laser Head and Controller

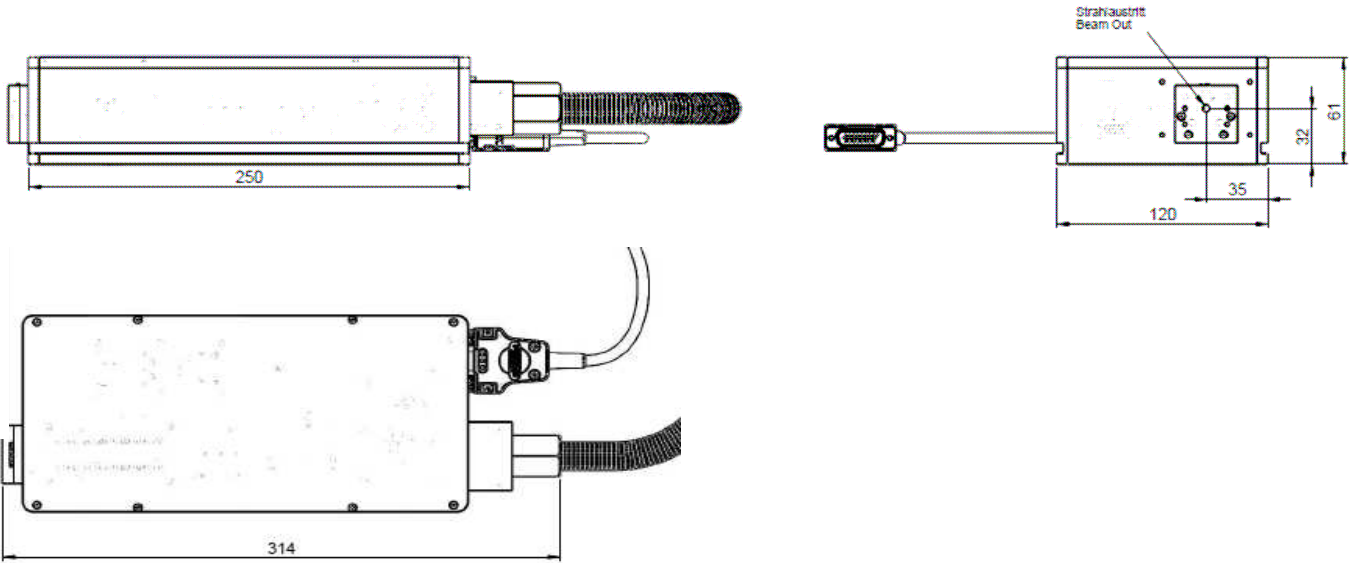

Laser Head
(height = 61; width = 120; length = 314
core dimensions in mm)

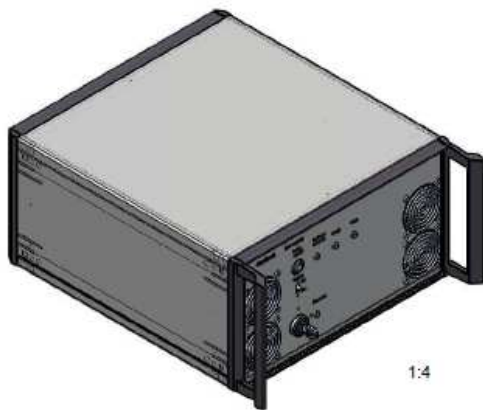

Controller
(height = 184; width = 343; length = 375
core dimensions in mm)

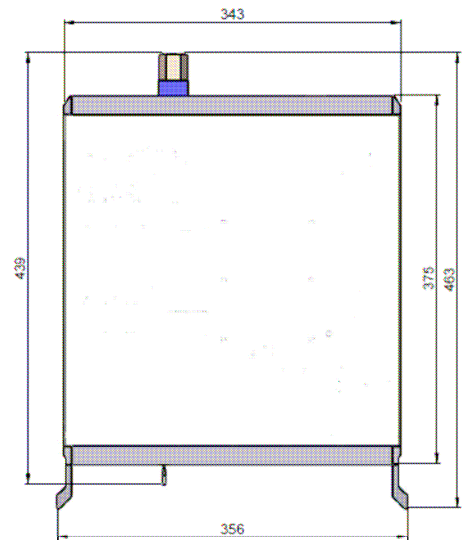

Laser Safety Labels

The MOPA 1064-650 lasers are class 4 according to IEC 60825-1

